

# Monthly Space News

Greg Stanley

Nov. 12, 2022



# This month's news highlights...

- Planetary defense: DART asteroid crash update
- MOXIE oxygen generation on Mars update
- Chinese Space Station Phase I complete
- Inflatable reentry heat shield demo
- Upcoming November 22 Moon launch
  - Lander, and "Lunar Flashlight" to find ice
- Recent launches to space

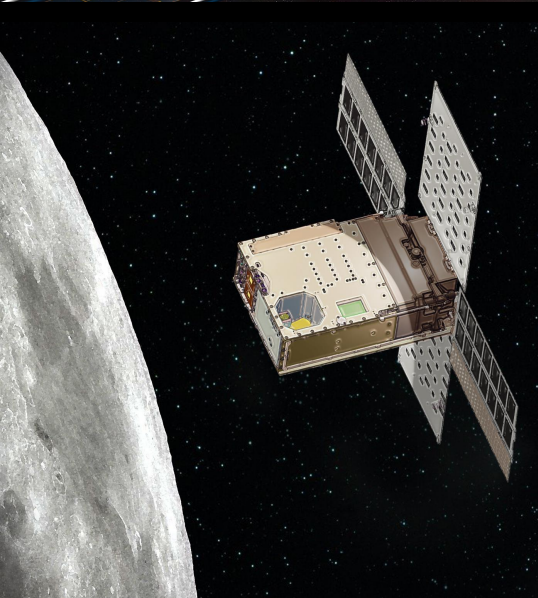
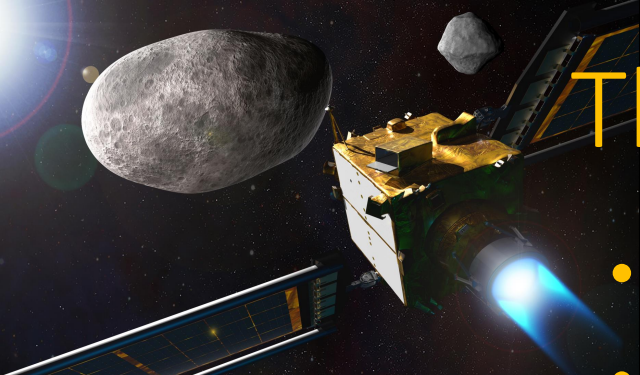
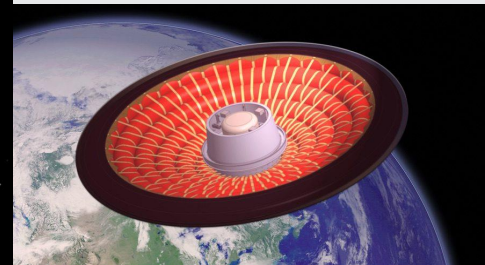
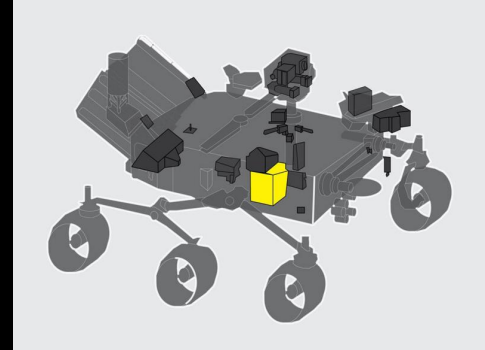

# DART (Double Asteroid Redirection Test) update

- Sept. 26 Test of planetary defense, crashing into a binary asteroid moonlet (Dimorphos) at 15,000 mph



Didymos  
2560 ft. diameter

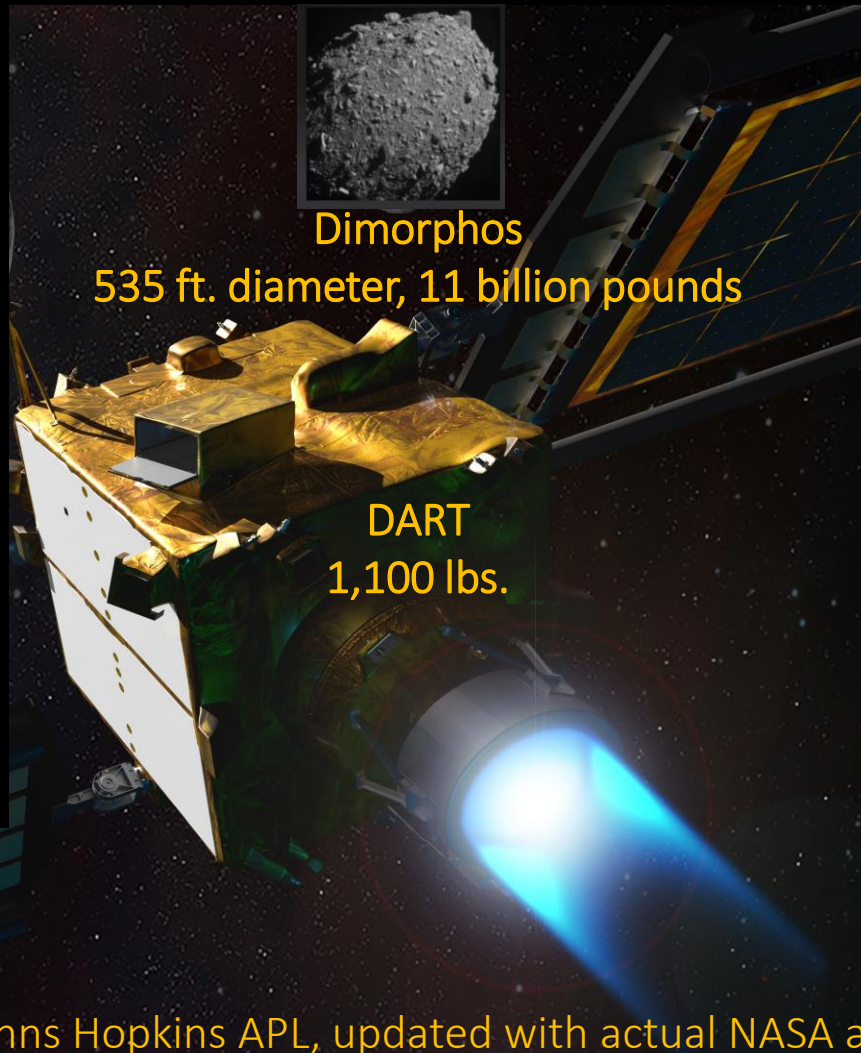

Dimorphos

535 ft. diameter, 11 billion pounds

DART  
1,100 lbs.

- Effects recorded by Hubble & James Webb space telescopes, LICIACube local cubesat, others
- Measured orbital period of Dimorphos around Didymos by variations in light from the combined system

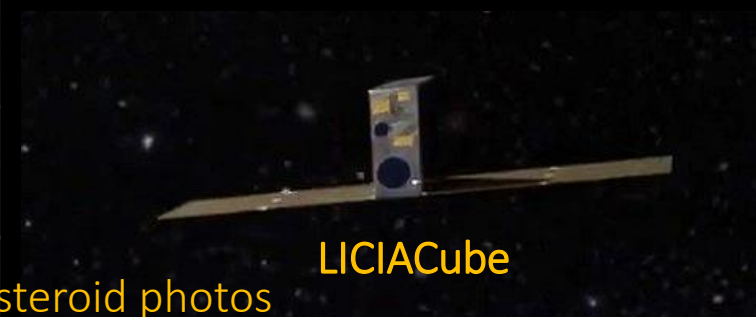

LICIACube

# DART effectiveness was greater than expected

- Shortened 12 hour Dimorphos orbit around Didymos by 32 minutes
  - More than expected
  - Probably due to rubble pile” nature of Dimorphos
  - Ejected material carries away momentum/energy (asymmetrically)
- Effect on combined binary system orbit may take a few years to pinpoint
  - ESA project on stellar occultation (noting dimming when crossing in front of a star)
- Scientists haven’t yet explained the twin comet-like tails



Didymos-Dimorphos system several weeks after DART impact  
Hubble Space Telescope photo. Credit: NASA/ESA/PSI/STScI  
([esahubble.org/images/opo22056a/](https://esahubble.org/images/opo22056a/))



Asteroid occulting a distant star  
Credit: NASA/ESA/Greg Bacon (STScI)  
[www.esa.int/ESA\\_Multimedia/Images/2022/10/](http://www.esa.int/ESA_Multimedia/Images/2022/10/)

# MOXIE (Mars Oxygen In-Situ Resource Utilization Experiment): update

- MOXIE generates O<sub>2</sub> from Mars 95% CO<sub>2</sub> atmosphere
  - Built into the Perseverance rover
  - $2 \text{ CO}_2 \rightarrow 2 \text{ CO} + \text{O}_2$  using “solid oxide electrolyzer cell”
  - Test: Up to 10 g/hr O<sub>2</sub> , comparable to a medium tree
  - 38 lbs, uses 300 watts of power (100 average available)
  - First demo of ISRU on another planetary body
- Why? Long term sustainability: breathing, fuel
- Why not ice instead (needed long term for the hydrogen atoms)?
  - Electrolyzing water would take ice mining, melting, purification, transport
  - More complex for initial landings, automated operations ahead of human landing
- Paper published on results of this Technology Demonstration
  - 6 g/hr O<sub>2</sub> at 7 various conditions (day/night/season → P, T; density varies 2x)
  - Coking (carbon deposition) & catalyst oxidation or other degradation avoided

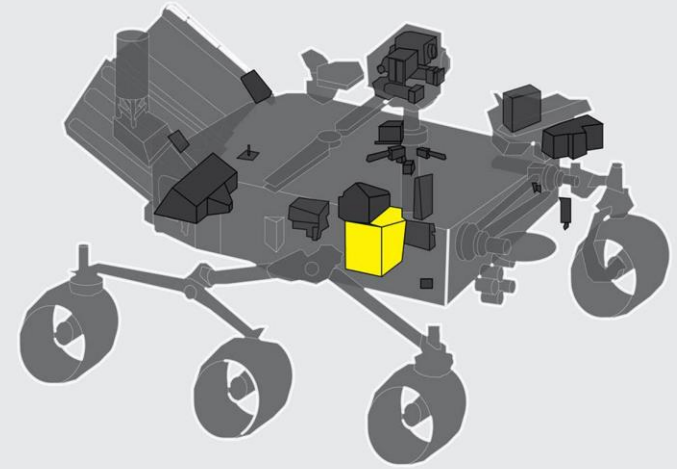

MOXIE location on Perseverance

# MOXIE details

- The equipment
  - Pleated HEPA filter to trap dust (OK short term)
  - Compressor increases pressure 100x to Earth's
  - Heater plates heat to 800 °C (1,472 °F)
  - Voltage & nickel-based catalyst decomposes CO<sub>2</sub> to Oxygen ions & CO
  - Ceramic passes ions, recombining into 99.6% O<sub>2</sub>
- Intermittent test runs (7 so far)
  - Electrolyzer ceramic heated (2 hours)
  - 1-hour runs, shutting most other things down

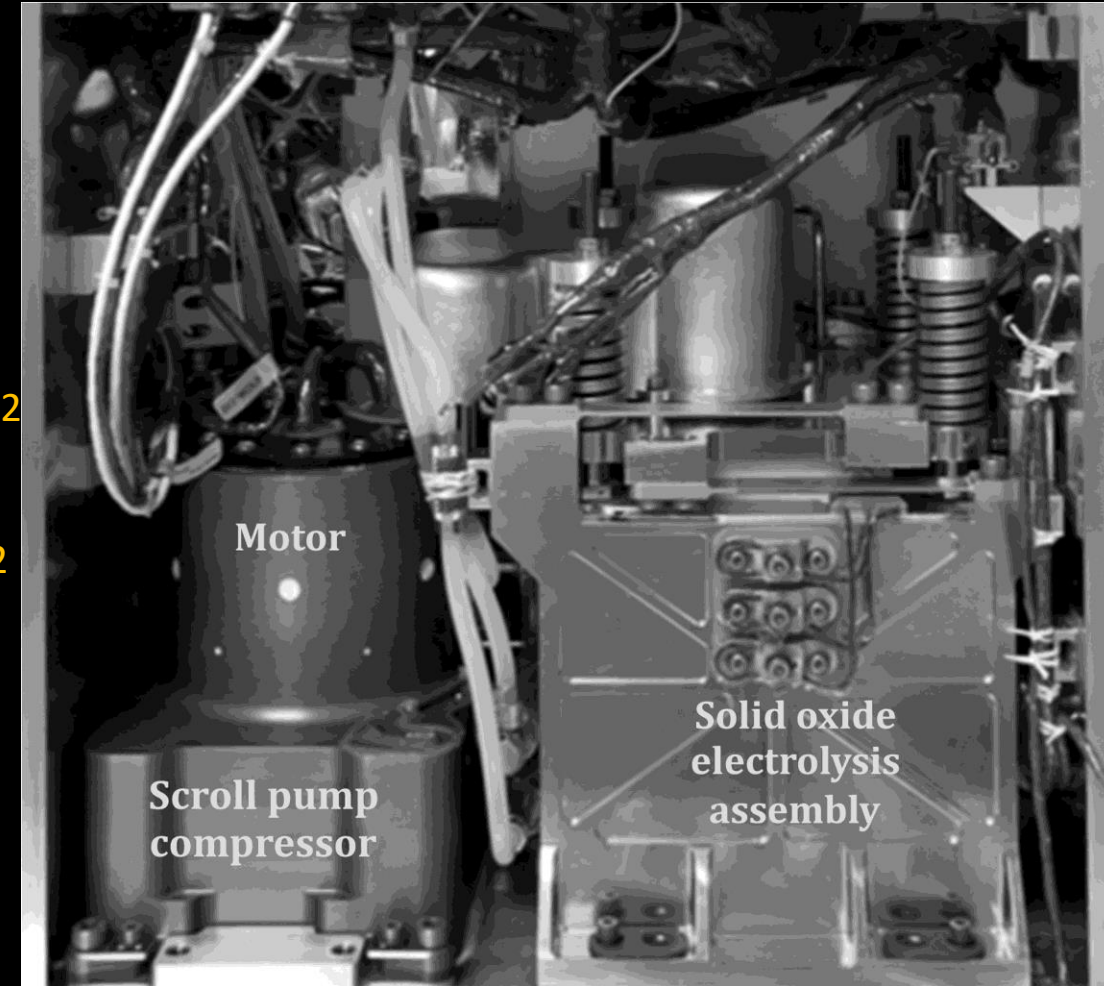

MOXIE, without cover, inlet filter, sensors, flow control panel, electronics  
Credit: <https://www.science.org/doi/10.1126/sciadv.abp8636>

# Will MOXIE scale up for actual use?

- Breathing air needs
  - MOXIE 6 g/hr vs. 35 g/hr needed for 1 astronaut
  - 18 month stay for several humans: 2-3 tons O<sub>2</sub>
- Fuel for 6-human crew return to Earth (50 ton ascent)
  - Propellant example: 31 tons O<sub>2</sub> , 9 tons methane
  - Need roughly 2-3 kg/hr for 20-26 months
- “Big MOXIE” would need 25-30 KW power plant
- Won't directly scale up, but modified version should.  
NASA has 3 contracts with OxEon .

# Chinese space station phase I completed

- Third module Mengtian added Oct. 31
  - Long March 5B Heavy lift rocket core fell uncontrolled to Earth (like previous 3 times)
- Phase I complete (but can be expanded)
  - Capacity: 6 crew, currently 3 aboard
  - Mass: about 1/5 of ISS, similar to old Mir
  - Pressurized volume: 11,300 cu. Ft.
  - Typical altitude: 383 km ( 238 miles)
  - 5 robotic arms
- 2024: co-orbiting Hubble-class telescope

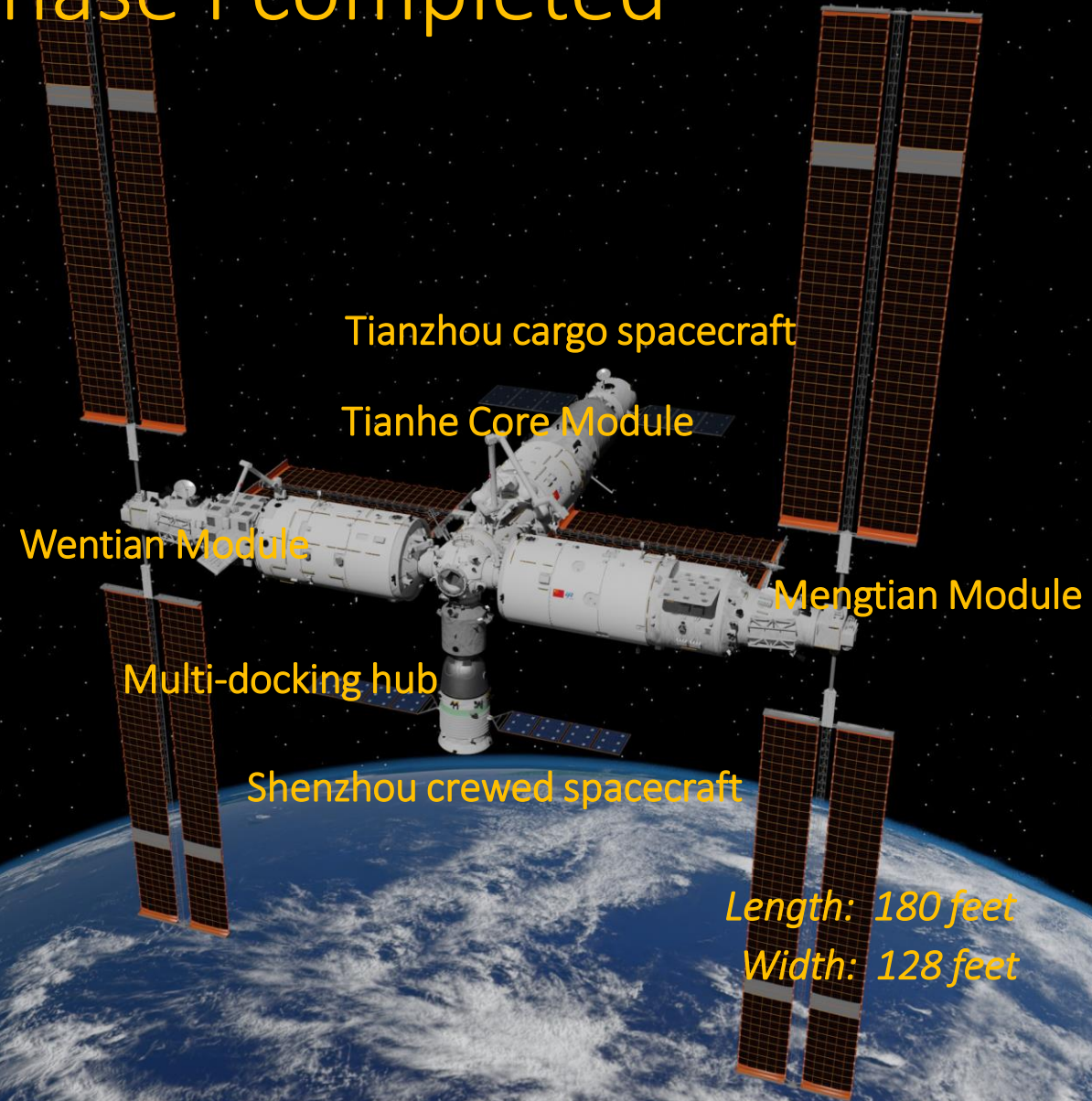

# LOFTID inflatable heat shield technology demonstration

- LOFTID = Low Earth Orbital Flight Test of an Inflatable Decelerator (NASA)
- Inflatable heat shield is bigger than fairing diameter, to increase reentry drag
  - Especially needed for Mars thin atmosphere, especially higher elevations
  - Recover large rocket stages, e.g., engine section of Vulcan rocket
  - Bring more mass back from ISS or in-space manufacturing
- Secondary payload on weather satellite launch Nov. 10
  - Deployed on Centaur upper stage, then detached for test
  - LOFTID diameter is 6 meters (19.7 ft.), from 4m fairing
  - Slow from orbital velocity to Mach 0.7
    - 1,400 °C (2552 °F), deceleration up to 9G
  - Parachute to ocean for recovery
- Real applications would be much bigger
  - 12-14m for Vulcan, 16m for Mars lander

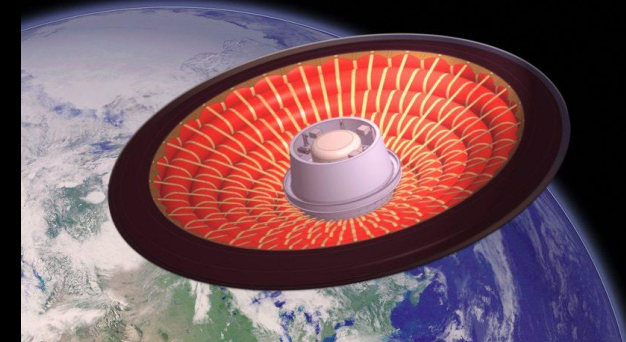

# Upcoming November 22 Falcon 9 launch to the Moon

- ispace (Japanese) Hakuto-R M1 lander
  - United Arab Emirates Rashid 1 rover inside
  - Japanese baseball-sized “transformer” robot inside
  - Other small payloads inside
- Lunar flashlight (6U cubesat)



# Lunar Flashlight

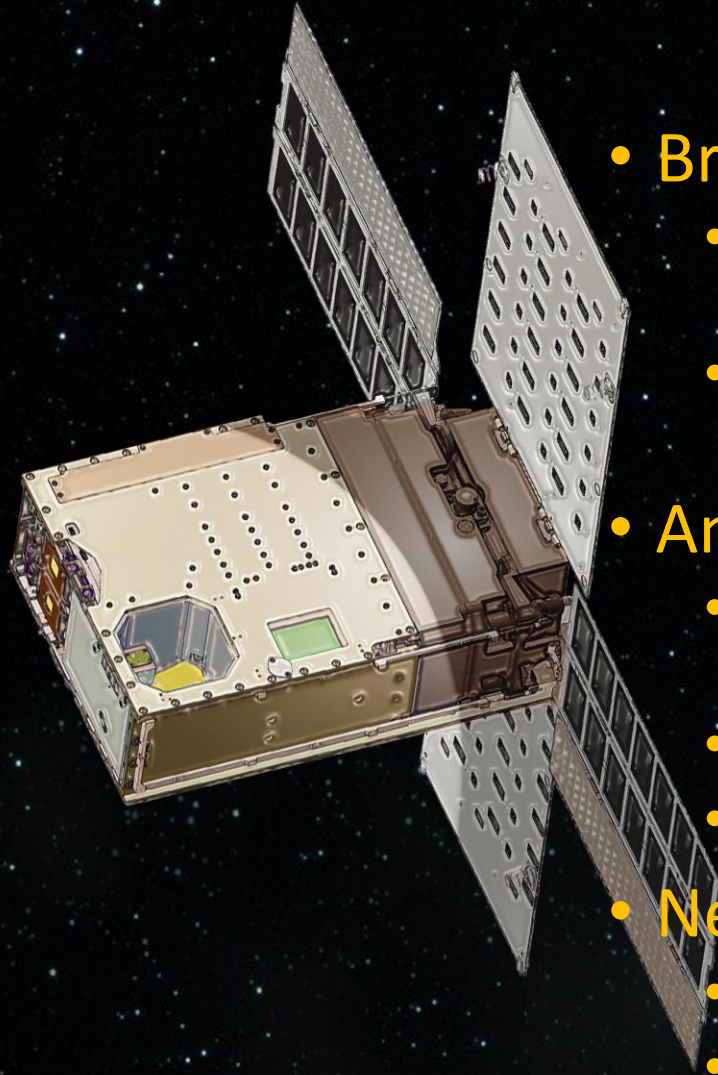

- Briefcase-sized lunar satellite to find ice
  - 6U cubesat will search permanently dark craters at lunar south pole
  - 4 near-infrared laser beams absorbed by ice, reflected from rock
- Another Near Rectilinear Halo Orbit
  - Highly eccentric: 42,000 miles to 9 miles above lunar South Pole
  - Requires little fuel – like CAPSTONE mission
  - 3 months to reach orbit – passing Moon first
- New ASCENT monopropellant
  - Burns via catalyst: no separate oxidizer
  - Much less toxic, more efficient than hydrazine
  - No heater needed to prevent freezing
  - First tested in orbit in 2019

Image: NASA

# Miscellany

- Blue Origin (finally) delivered 2 BE-4 engines for ULA's new Vulcan rocket
- China's future Long March 9 heavy lift rocket will now have a re-usable first stage
  - Earlier plans were comparable to SLS: expendable, with side-mounted boosters
  - New huge million-pound thrust engine might not be suitable, since only one of a cluster of smaller engines is enough to land empty booster (like Falcon & Starship)













# How many launches since the last meeting (Oct. 8)?

*Includes failed launches if they lift off the launch pad  
Only includes launches attempting Earth orbit or beyond*















Falcon 9 Heavy rocket launching U.S. Space Force  
classified mission 11/01/2022  
First Falcon Heavy mission in over 3 years  
Worlds most powerful operational rocket  
Credit: SpaceX (video)



# Launches since last meeting (Oct. 8), page 1

-  Oct 08 – Falcon 9 – 2 Intelsat geo orbit comms satellites (Galaxy 33 & 34)
-  Oct 08 – Long March 2D – Advanced Space-borne Solar Observatory (ASO-S)
-  Oct 09 – Soyuz 2.1b – a GLONASS-K1 navigation satellite
-  Oct 11 – Epsilon (Japan) – RAISE-3 payload demonstration + rideshares (FAIL)
-  Oct 12 – Proton-M (*nearly the last*) – Angosat-2 geo orbit comms satellite for Angola
-  Oct 12 -- Long March 2C – Huanjing-2E radar Earth observation satellite
-  Oct 14 – Long March 2D – 3 Yaogan military reconnaissance satellites
-  Oct 15 – Falcon 9 – Eutelsat Hotbird-13F geo orbit comms satellite
-  Oct 15 – Angara-1.2 (*replaces Proton*) – Russian military satellite (Kosmos 2560)
-  Oct 20 – Falcon 9 – 54 Starlink internet satellites
-  Oct 21 – Soyuz-2 – 2 Russian military satellites Kosmos-2561/2562
-  Oct 22 – GSLV-III (India) – 36 OneWeb internet satellites
-  Oct 22 – Soyuz-2 – 3 comms satellites (Gonets-M 23/24/25) + internet test satellite

# Launches since last meeting (Oct. 8), page 2

-  Oct 25 – Soyuz 2 – Progress cargo ship to ISS (space station)
-  Oct 27 – Falcon 9 – 53 Starlink internet satellites (3,558 launched so far)
-  Oct 28 – Long March 2D – Shiyan-20C classified satellite (now 22 in Shiyan constellation)
-  Oct 31 – Long March 5B – Mengtian science module to Chinese space station
-  Nov 01 – Falcon Heavy – USSF classified geo orbit mission: TETRA-1 + rideshares
-  Nov 02 – Soyuz-2.1b – Russian military satellite (early warning system) Kosmos-2563
-  Nov 03 – Falcon 9 – Eutelsat Hotbird 13G geo orbit comms satellite
-  Nov 04 – Electron – Swedish MATS science satellite (success, except didn't catch booster)
-  Nov 05 – Long March 3B/E – Zhongxing (ChinaSat) geo orbit comms satellite
-  Nov 07 – Antares 230+ (Ukrainian 1<sup>st</sup> stage) – Cygnus cargo ship to ISS (space station)
-  Nov 10 – Atlas V – JPSS-2 (Joint Polar Satellite System) weather satellite, LOFTID
-  Nov 11 – Long March 6A – Yunhai-3 – Earth observation satellite
-  Nov 11 – Long March 7 – Tianzhou-5 – Cargo to the Chinese Space Station
-  Nov 12 – Falcon 9 – 2 Intelsat geo orbit satellites. Expendable mode (14<sup>th</sup> flight/ extra \$)

What those Intelsat satellites  
look like stacked as payload



Photo credit: Intelsat

# Discussion & questions?



Image: NASA



# Featured speaker: Chris Kapp

- Turbomachinery and business consultant
- Professor of engineering at Lone Star College
- Started a turbomachinery joint venture in India
- NSS Space Ambassador
- MS Aeronautical Engineering, RWTH Aachen University (Germany)
  - Exchange student at Norwegian University of Science & Technology, Trondheim
- NSS North Houston board member
- Volunteer for NASA Hunch program, Science & Engineering Fair Houston, Engineers Without Borders, Red Cross, ...

TOPIC: How to move fast in the Solar System